

# INTERNATIONAL STANDARD

**ISO  
9117-4**

First edition  
2012-08-15

---

---

## **Paints and varnishes — Drying tests —**

**Part 4:**

### **Test using a mechanical recorder**

*Peintures et vernis — Essais de séchage —*

*Partie 4: Essai à l'aide d'un enregistreur mécanique*



Reference number  
ISO 9117-4:2012(E)

© ISO 2012

标格达仪器  
www.biuged.com

标格达仪器  
www.biuged.com

标格达仪器  
www.biuged.com

标格达仪器  
www.biuged.com

标格达仪器  
www.biuged.com

标格达仪器  
www.biuged.com

标格达仪器  
www.biuged.com

标格达仪器  
www.biuged.com

标格达仪器  
www.biuged.com

标格达仪器  
www.biuged.com



**COPYRIGHT PROTECTED DOCUMENT**

© ISO 2012

All rights reserved. Unless otherwise specified, no part of this publication may be reproduced or utilized in any form or by any means, electronic or mechanical, including photocopying and microfilm, without permission in writing from either ISO at the address below or ISO's member body in the country of the requester.

ISO copyright office  
Case postale 56 • CH-1211 Geneva 20  
Tel. + 41 22 749 01 11  
Fax + 41 22 749 09 47  
E-mail [copyright@iso.org](mailto:copyright@iso.org)  
Web [www.iso.org](http://www.iso.org)

Published in Switzerland

标格达仪器  
www.biuged.com

# Contents

Page

Foreword.....	iv
Introduction.....	v
1 Scope.....	1
2 Normative references.....	1
3 Principle.....	1
3.1 Straight-line recorder.....	1
3.2 Circular recorder.....	1
4 Sampling.....	1
5 Test panels.....	2
5.1 Substrate.....	2
5.2 Coating of test panels.....	2
6 Test conditions and number of tests.....	2
7 Method A — Using a straight-line drying-time recorder.....	2
7.1 Apparatus.....	2
7.2 Procedure.....	2
8 Method B — Using a circular drying-time recorder.....	3
8.1 Apparatus.....	3
8.2 Procedure.....	3
9 Classification of drying stages.....	4
10 Precision.....	5
11 Test report.....	5

## Foreword

ISO (the International Organization for Standardization) is a worldwide federation of national standards bodies (ISO member bodies). The work of preparing International Standards is normally carried out through ISO technical committees. Each member body interested in a subject for which a technical committee has been established has the right to be represented on that committee. International organizations, governmental and non-governmental, in liaison with ISO, also take part in the work. ISO collaborates closely with the International Electrotechnical Commission (IEC) on all matters of electrotechnical standardization.

International Standards are drafted in accordance with the rules given in the ISO/IEC Directives, Part 2.

The main task of technical committees is to prepare International Standards. Draft International Standards adopted by the technical committees are circulated to the member bodies for voting. Publication as an International Standard requires approval by at least 75 % of the member bodies casting a vote.

Attention is drawn to the possibility that some of the elements of this document may be the subject of patent rights. ISO shall not be held responsible for identifying any or all such patent rights.

ISO 9117-4 was prepared by Technical Committee ISO/TC 35, *Paints and varnishes*, Subcommittee SC 9, *General test methods for paints and varnishes*.

ISO 9117 consists of the following parts, under the general title *Paints and varnishes — Drying tests*:

- *Part 1: Determination of through-dry state and through-dry time*
- *Part 2: Pressure test for stackability*
- *Part 3: Surface-drying test using ballotini*
- *Part 4: Test using a mechanical recorder*
- *Part 5: Modified Bandow-Wolff test*
- *Part 6: Print-free test*

## Introduction

The drying time of a coating is significant in determining when a freshly painted room, floor or stairway may be put back in use or when a freshly coated article may be handled or packaged. Slow drying might result in dirt pick-up or, on an exterior surface, moisture might cause a non-uniform appearance.

The test described in this part of ISO 9117 is used to determine, using a mechanical recorder, the various stages of drying or curing in the dry-film formation of organic coatings for the purpose of comparing types of coating or ingredient changes, or both. To evaluate the stages of drying in a quantitative manner, the use of the recorder under controlled environmental conditions is strongly recommended. The use of a mechanical recorder also offers a method of determining the drying characteristics of coatings that cannot be ascertained within the standard 8 h working day.

This test is useful in comparing the behaviour, during drying, of coatings of the same generic type. Determination of actual drying times should be conducted following procedures specified e.g. in ISO 9117-1 or ISO 9117-3.

标格达仪器  
www.biuged.com

# Paints and varnishes — Drying tests —

## Part 4: Test using a mechanical recorder

### 1 Scope

This part of ISO 9117 specifies a test for determining the times taken to reach various stages of drying of organic coatings, using a mechanical straight-line or circular drying-time recorder. The use of a mechanical recorder is valuable in comparing the drying behaviour of coatings of the same generic type, when one coating might form a gel at a faster rate than another or might resist scratching better than another. The test is intended to simulate the conditions which exist when painted articles are stacked upon each other.

### 2 Normative references

The following referenced documents are indispensable for the application of this document. For dated references, only the edition cited applies. For undated references, the latest edition of the referenced document (including any amendments) applies.

ISO 1513, *Paints and varnishes — Examination and preparation of test samples*

ISO 1514, *Paints and varnishes — Standard panels for testing*

ISO 2808, *Paints and varnishes — Determination of film thickness*

ISO 3270, *Paints and varnishes and their raw materials — Temperatures and humidities for conditioning and testing*

ISO 15528, *Paints, varnishes and raw materials for paints and varnishes — Sampling*

### 3 Principle

#### 3.1 Straight-line recorder

In method A (using a straight-line recorder), the coating is applied to glass strips measuring at least 300 mm × 25 mm. The strips are positioned so that a stylus can be lowered into the wet film on each. The styluses move along the glass strips at a selected constant speed.

#### 3.2 Circular recorder

In method B (using a circular recorder), the coating is applied to a glass plate measuring approximately 150 mm × 150 mm. The drying-time recorder is immediately placed on the wet film and a stylus lowered into the film and moved in a 360° arc at a selected constant speed.

### 4 Sampling

Take a representative sample of the product to be tested (or of each product in the case of a multi-coat system), as described in ISO 15528.

Examine and prepare each sample for testing, as described in ISO 1513.

## 5 Test panels

### 5.1 Substrate

Use clean glass panels as described in ISO 1514.

### 5.2 Coating of test panels

Prepare each test panel in accordance with ISO 1514 and then coat it by the specified method with the product or system under test.

The coating method and dry-film thickness shall be as specified by the manufacturer or as agreed between interested parties, and shall be included in the test report [Clause 11, item c) 2)].

## 6 Test conditions and number of tests

Carry out the procedure at least in duplicate at  $(23 \pm 2)$  °C and ambient relative humidity, unless otherwise agreed (see also ISO 3270).

## 7 Method A — Using a straight-line drying-time recorder

### 7.1 Apparatus

**7.1.1 Straight-line drying-time recorder**, fitted with multiple styluses 2 mm in diameter, with rounded tips, which are drawn over multiple coated glass panels, typically measuring 300 mm × 25 mm, disposed parallel to each other. The stylus arm generally comes with 5 g weights that may be added to apply greater pressure on the styluses and thus record the through-dry time. Other weights may be used as agreed between the interested parties. The speed can be varied to cover drying periods of 6 h, 12 h and 24 h.

### 7.1.2 Magnifying glass.

### 7.2 Procedure

Apply the coating to the glass strips. Record the time of application. Immediately attach the glass strips to the recorder and lower the stylus arm so that it is at the starting position. Lower the styluses gently into position on their respective strips. Before use, always ensure that the tips of the styluses are clean and free from dried paint from previous tests. Switch on the motor and the styluses will be drawn along their respective strips by the stylus arm.

Always mark the point on the glass strip where the stylus is first lowered into the wet film by use of a marker pen or a similar method. This will aid in measuring times along the strip during the assessment stage, as it is often not obvious at what point the track starts since paint flows back into the groove.

After drying, evaluate the glass strips by reference to Figure 1 to determine the time at which the stage of interest was reached, and record this time. The use of a magnifying glass will enhance the evaluation. The drying time is the quotient of the distance covered at each stage and the speed of the stylus.

Determine the thickness, in micrometres, of the dried coating by one of the procedures specified in ISO 2808.



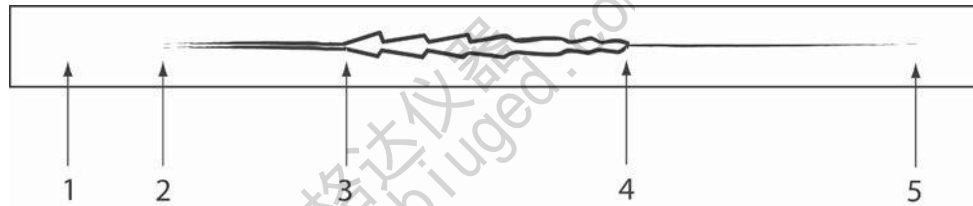

### Key

- 1 start
- 2 set-to-touch time
- 3 tack-free time
- 4 hard-dry time
- 5 through-dry time

Figure 1 — Stages of drying using a straight-line drying-time recorder

## 8 Method B — Using a circular drying-time recorder

### 8.1 Apparatus

**8.1.1 Circular drying-time recorder**, with a motor that is mounted on a rubber-shod tripod. The motor shaft is oriented vertically, with a pivoting-arm assembly attached to it to operate a counterpoised vertical stylus, made of PTFE, with an end approximately 10 mm in diameter. The PTFE stylus, typically weighted with a load of 12 g, scribes an arc in the drying film. The arm assembly includes a counterweight to permit adjustment of the pressure on the needle to near zero. The stylus is moved in a circular arc at a selected constant speed. Recorders are available to cover various drying times, such as 1 h, 6 h, 12 h or 24 h.

**8.1.2 Transparent template**, with scale graduations corresponding to the particular motor speed, for timing the various stages of drying revealed by differences observed in the scribed pattern.

**8.1.3 Magnifying glass.**

### 8.2 Procedure

Prepare test panels as specified in Clause 5. Glass plates measuring about 150 mm × 150 mm are used for the determination of drying times with this type of recorder.

Apply the coating to a glass plate. Record the time of application. Immediately attach the glass plate to the recorder, and lower the stylus gently into position on the panel. Before use, always ensure that the tip of the stylus is clean and free from dried paint from previous tests. Switch on the motor so the stylus is drawn round the glass plate.

Always mark the point where the stylus is first lowered into the wet film by use of a marker pen or a similar method. This will aid in measuring times along the track during the assessment stage, as it is often not obvious at what point the track starts since paint flows back into the groove.

After drying, use the transparent template to evaluate the glass plate by reference to Figure 2 to determine the time at which the stage of interest was reached, and record this time. The use of a magnifying glass will enhance the evaluation. The drying time is the quotient of the distance covered at each stage and the speed of the stylus.

Determine the thickness, in micrometres, of the dried coating by one of the procedures specified in ISO 2808.

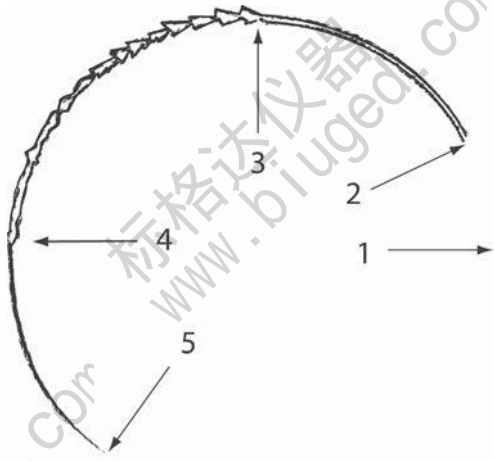

**Key**

- 1 start
- 2 set-to-touch time
- 3 tack-free time
- 4 hard-dry time
- 5 through-dry time

**Figure 2 — Stages of drying using a circular drying-time recorder**

**9 Classification of drying stages**

The classification given in Table 1 is typical for coatings that do not skin over during curing. Any coating which exhibits skinning, such as two-pack epoxy or polyurethane coatings, will show a very different track where the stylus tears the surface of the film, leaving diamond- or kite-shaped patterns.

Table 1 — Classification of drying stages

Stage of drying	Description	Observation during test
Set-to-touch time	Film has solidified sufficiently, by solvent evaporation or chemical reaction, or both, that it no longer flows or sticks to a finger that lightly touches it.	The set-to-touch time is reached when a pear-shaped depression appears in the film and the film stops flowing over the path of the stylus and leaves a track in the film revealing the glass substrate (see Figure 1 and Figure 2).
Tack-free time	Period of time till condition reached when the film surface has dried or cured (see set-to-touch time) so that the film does not adhere to very light objects placed on it.	The tack-free time is reached when the continuous track in the film ceases and the stylus starts to tear the film or leave a ragged/ sharp-edged groove as it begins to climb over the film (see Figure 1 and Figure 2).
Hard-dry time	Period of time till condition reached when the drying or curing reaction, or both, has proceeded sufficiently that the film is not displaced, nor is any noticeable mark left, when the panel is pinched between the thumb on the film and forefinger with a relatively strong force.	The hard-dry time is reached when the stylus rises out of the film and rides on the surface, leaving only a mark and without disrupting the body of the film (see Figure 1 and Figure 2).
Through-dry time	Period of time till condition reached when the film has solidified so completely that a large, twisting force can be applied without distorting the film.	The through-dry time is reached when the stylus no longer leaves any visible mark on the film (see Figure 1 and Figure 2)

## 10 Precision

No precision data are currently available.

## 11 Test report

The test report shall include the following information:

- a) all details necessary to identify the product under test;
- b) a reference to this part of ISO 9117 (ISO 9117-4);
- c) details of the preparation of the test panels, including
  - 1) the material (including thickness) and surface preparation of the substrate (see 5.1),
  - 2) the method of application of the test coating to the substrate, including the duration and conditions of drying between coats in the case of a multi-coat system (see 5.2);
- d) the type of mechanical drying-time recorder used;
- e) the time taken to reach each drying stage;
- f) any deviation, by agreement or otherwise, from the test procedure specified;
- g) any unusual features (anomalies) observed during the test;
- h) the date of the test.

---

---

**ICS 87.040**

Price based on 5 pages