



BSI Standards Publication

Paints and varnishes - Determination of resistance to liquids

Part 5: Temperature-gradient oven method

EUROPEAN STANDARD

EN ISO 2812-5

NORME EUROPÉENNE

EUROPÄISCHE NORM

September 2018

ICS 87.040

Supersedes EN ISO 2812-5:2007

English Version

Paints and varnishes - Determination of resistance to liquids - Part 5: Temperature-gradient oven method (ISO 2812-5:2018)

Peintures et vernis - Détermination de la résistance aux liquides - Partie 5: Méthode au four à gradient de température (ISO 2812-5:2018)

Beschichtungsstoffe - Bestimmung der Beständigkeit gegen Flüssigkeiten - Teil 5: Verfahren mit dem Gradientenofen (ISO 2812-5:2018)

This European Standard was approved by CEN on 12 August 2018.

CEN members are bound to comply with the CEN/CENELEC Internal Regulations which stipulate the conditions for giving this European Standard the status of a national standard without any alteration. Up-to-date lists and bibliographical references concerning such national standards may be obtained on application to the CEN-CENELEC Management Centre or to any CEN member.

This European Standard exists in three official versions (English, French, German). A version in any other language made by translation under the responsibility of a CEN member into its own language and notified to the CEN-CENELEC Management Centre has the same status as the official versions.

CEN members are the national standards bodies of Austria, Belgium, Bulgaria, Croatia, Cyprus, Czech Republic, Denmark, Estonia, Finland, Former Yugoslav Republic of Macedonia, France, Germany, Greece, Hungary, Iceland, Ireland, Italy, Latvia, Lithuania, Luxembourg, Malta, Netherlands, Norway, Poland, Portugal, Romania, Serbia, Slovakia, Slovenia, Spain, Sweden, Switzerland, Turkey and United Kingdom.



EUROPEAN COMMITTEE FOR STANDARDIZATION
COMITÉ EUROPÉEN DE NORMALISATION
EUROPÄISCHES KOMITEE FÜR NORMUNG

CEN-CENELEC Management Centre: Avenue Marnix 17, B-1000 Brussels

European foreword

This document (EN ISO 2812-5:2018) has been prepared by Technical Committee ISO/TC 35 "Paints and varnishes" in collaboration with Technical Committee CEN/TC 139 "Paints and varnishes" the secretariat of which is held by DIN.

This European Standard shall be given the status of a national standard, either by publication of an identical text or by endorsement, at the latest by March 2019, and conflicting national standards shall be withdrawn at the latest by March 2019.

Attention is drawn to the possibility that some of the elements of this document may be the subject of patent rights. CEN shall not be held responsible for identifying any or all such patent rights.

This document supersedes EN ISO 2812-5:2007.

According to the CEN-CENELEC Internal Regulations, the national standards organizations of the following countries are bound to implement this European Standard: Austria, Belgium, Bulgaria, Croatia, Cyprus, Czech Republic, Denmark, Estonia, Finland, Former Yugoslav Republic of Macedonia, France, Germany, Greece, Hungary, Iceland, Ireland, Italy, Latvia, Lithuania, Luxembourg, Malta, Netherlands, Norway, Poland, Portugal, Romania, Serbia, Slovakia, Slovenia, Spain, Sweden, Switzerland, Turkey and the United Kingdom.

Endorsement notice

The text of ISO 2812-5:2018 has been approved by CEN as EN ISO 2812-5:2018 without any modification.

Contents

Page

Foreword	iv
1 Scope	1
2 Normative references	1
3 Terms and definitions	1
4 Principle	1
5 Limitations	2
6 Apparatus	2
7 Test substances	2
8 Sampling	2
9 Test panels	2
9.1 Substrate	2
9.2 Preparation and coating	3
9.3 Coating thickness	3
10 Procedure	3
10.1 Conditioning of the test panels	3
10.2 Test conditions	3
10.3 Determination	3
11 Evaluation	3
12 Precision	4
12.1 Repeatability limit (<i>r</i>)	4
12.2 Reproducibility limit (<i>R</i>)	4
13 Test report	4
Annex A (informative) Examples of test substances	5
Bibliography	7

Foreword

ISO (the International Organization for Standardization) is a worldwide federation of national standards bodies (ISO member bodies). The work of preparing International Standards is normally carried out through ISO technical committees. Each member body interested in a subject for which a technical committee has been established has the right to be represented on that committee. International organizations, governmental and non-governmental, in liaison with ISO, also take part in the work. ISO collaborates closely with the International Electrotechnical Commission (IEC) on all matters of electrotechnical standardization.

The procedures used to develop this document and those intended for its further maintenance are described in the ISO/IEC Directives, Part 1. In particular the different approval criteria needed for the different types of ISO documents should be noted. This document was drafted in accordance with the editorial rules of the ISO/IEC Directives, Part 2 (see www.iso.org/directives).

Attention is drawn to the possibility that some of the elements of this document may be the subject of patent rights. ISO shall not be held responsible for identifying any or all such patent rights. Details of any patent rights identified during the development of the document will be in the Introduction and/or on the ISO list of patent declarations received (see www.iso.org/patents).

Any trade name used in this document is information given for the convenience of users and does not constitute an endorsement.

For an explanation on the voluntary nature of standards, the meaning of ISO specific terms and expressions related to conformity assessment, as well as information about ISO's adherence to the World Trade Organization (WTO) principles in the Technical Barriers to Trade (TBT) see the following URL: www.iso.org/iso/foreword.html.

This document was prepared by Technical Committee ISO/TC 35, *Paints and varnishes*, Subcommittee SC 9, *General test methods for paints and varnishes*.

This second edition cancels and replaces the first edition ([ISO 2812-5:2007](http://www.iso.org/iso/2812-5:2007)), which has been technically revised. The main changes compared to the previous edition are as follows:

- a) [Clause 3](#) and [Clause 5](#) have been added;
- b) in [6.1](#), the description of the gradient oven has been amended;
- c) in [10.3](#), the distance of the individual heating segments for a temperature increase of 1 °C has been clarified to 1 cm;
- d) in [Clause 11](#), reference to [ISO 13076](#) has been made for the lighting and procedure for visual assessment;
- e) in [Annex A](#), the CAS numbers have been added to the reagents listed.

A list of all parts in the [ISO 2812](#) series can be found on the ISO website.

Paints and varnishes - Determination of resistance to liquids —

Part 5: Temperature-gradient oven method

1 Scope

This document specifies a method, using a temperature-gradient oven, for determining the resistance of an individual-layer or multi-layer system of coating materials to the effects of liquids or paste-like products.

This method enables the testers to determine the effects of the test substance on the coating and, if necessary, to assess the damage to the substrate.

2 Normative references

The following documents are referred to in the text in such a way that some or all of their content constitutes requirements of this document. For dated references, only the edition cited applies. For undated references, the latest edition of the referenced document (including any amendments) applies.

[ISO 1513](#), *Paints and varnishes — Examination and preparation of test samples*

[ISO 1514](#), *Paints and varnishes — Standard panels for testing*

[ISO 2808](#), *Paints and varnishes — Determination of film thickness*

[ISO 3270](#), *Paints and varnishes and their raw materials — Temperatures and humidities for conditioning and testing*

[ISO 4618](#), *Paints and varnishes — Terms and definitions*

[ISO 13076](#), *Paints and varnishes — Lighting and procedure for visual assessments of coatings*

[ISO 15528](#), *Paints, varnishes and raw materials for paints and varnishes — Sampling*

3 Terms and definitions

For the purposes of this document, the terms and definitions given in [ISO 4618](#) apply.

ISO and IEC maintain terminological databases for use in standardization at the following addresses:

- IEC Electropedia: available at <http://www.electropedia.org/>
- ISO Online browsing platform: available at <https://www.iso.org/obp>

4 Principle

A test substance (see [Annex A](#)) is applied to a coated test panel following a specified procedure. The test panel is placed in a gradient oven. The effects of the exposures are assessed in accordance with agreed criteria.

5 Limitations

Temperature and humidity are important parameters affecting test results. Deviations from the requirements specified can lead to results that are not comparable. However, the interested parties may agree upon alternative parameters and these parameters shall be reported.

6 Apparatus

Ordinary laboratory equipment and the following apparatus.

6.1 Gradient oven, suitable for generating a linear temperature gradient over the length of the test panel, by heating the substrate from the bottom. The device shall be designed such that it has maximum gradients over the width of the panel of 2,5 °C. The heat transfer from the heater(s) to the substrate shall be such that a homogenous transfer can be produced (see [Figure 1](#)).

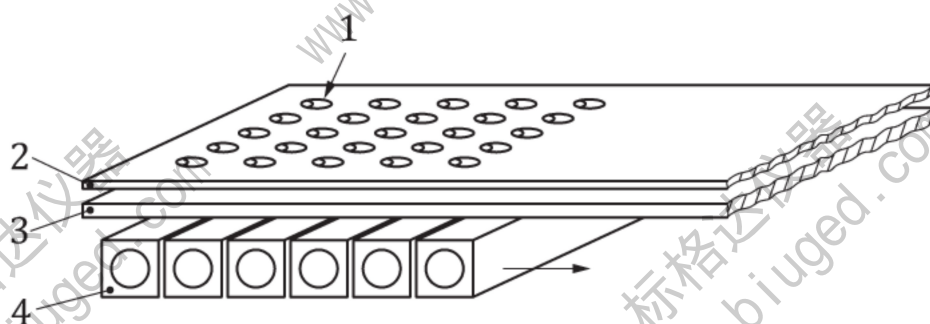

Key

- 1 test substance
- 2 test panel
- 3 special-purpose glass
- 4 heating elements

Figure 1 — Gradient-oven heating bench

6.2 Metering pipette, suitable for applying droplets of test substance with a volume from 25 µl to 100 µl.

7 Test substances

One or more test substances, as agreed between interested parties, shall be used. Examples of test substances are given in [Annex A](#).

8 Sampling

Take a representative sample of the coating material to be tested, in accordance with [ISO 15528](#).

Pretest each sample in accordance with [ISO 1513](#) and prepare it for further testing (see [9.2](#)).

9 Test panels

9.1 Substrate

Unless otherwise agreed, use steel test panels with dimensions of approximately 560 mm × 100 mm and a thickness of 0,7 mm to 1,0 mm.

9.2 Preparation and coating

Prepare each test panel as described in [ISO 1514](#) and then coat it by the specified application method with the product or system under test. Dry (or stove) and age (if applicable) each coated test panel for the specified time under specified conditions.

9.3 Coating thickness

Determine the dry film thickness of the coating, in micrometres, using one of the non-destructive methods specified in [ISO 2808](#).

10 Procedure

10.1 Conditioning of the test panels

Immediately before testing, condition the test panels for at least 16 h under standard conditions specified in [ISO 3270](#), i.e. (23 ± 2) °C and (50 ± 5) % relative humidity.

10.2 Test conditions

The gradient oven shall be placed in an environment at the standard temperature specified in [ISO 3270](#), i.e. (23 ± 2) °C.

10.3 Determination

Place the test panel horizontally. With the pipette, apply droplets of the liquid test substance (see examples in [Annex A](#)) to the test panel, spacing them at a distance corresponding to that between the individual heating segments of the gradient oven, if not otherwise agreed.

Application of the droplets should be carried out at room temperature (18 °C to 28 °C) with the panel placed on a laboratory table and not placed on the gradient oven.

Unless otherwise agreed, set the gradient oven at a gradient from 35 °C to 80 °C. The temperature gradient shall be created such that per 10 cm a temperature increase of 1 °C is created.

Push the prepared test panel into the gradient oven and press it to the heating bench using a pressing device. Expose the test panel in the gradient oven for 30 min then take it out of the oven.

11 Evaluation

After the test period has expired, wipe the test panel with a smooth cloth. Clean off any dried residue of aqueous test substances under running water, and clean off the dried residue of any other test substances with a solvent that does not attack the coating.

NOTE For some coating systems, dry-cleaning gasoline can be used for eliminating the resin. Dry-cleaning gasoline can also be used for the last cleaning of the panels before evaluation.

Evaluate only the area which has been in direct contact with the test substance.

Then immediately assess the test panel.

If not otherwise agreed, examine the panel as specified in [ISO 13076](#). The defects are best visible if the reflection of the light source is viewed together with the defect.

Unless otherwise agreed, reassess the exposed areas after 24 h.

Report the result as the temperature showing the first visible change.

12 Precision

12.1 Repeatability limit (r)

The repeatability limit (r) is the value below which the absolute difference between two single test results, each the mean of duplicates, can be expected to lie when this method is used under repeatability conditions. In this case, the test results are obtained on identical material, by one operator in one laboratory within a short interval of time using the standardized test method. In this document, (r) is 4 °C (± 2 °C), with a 95 % probability.

12.2 Reproducibility limit (R)

The reproducibility limit (R) is the value below which the absolute difference between two test results, each the mean of duplicates, can be expected to lie when this test method is used under reproducibility conditions. In this case, the test results are obtained on identical material, by operators in different laboratories using the standardized test method. In this document, (R) is 8 °C (± 4 °C), with a 95 % probability.

13 Test report

The test report shall contain at least the following information:

- a) all information necessary for identification of the sample tested;
- b) a reference to this document (i.e. [ISO 2812-5](#));
- c) details of the test panels, including:
 - 1) the material (including thickness) and surface pretreatment of the substrate;
 - 2) application method for applying the sample coating to the substrate, including the drying time and drying conditions for all layers; where applicable, ageing conditions before the test;
 - 3) dry film thickness of the coating in micrometres, including the measuring method as chosen in [ISO 2808](#);
- d) details of the method used, including the specification of the test substances;
- e) the temperature gradient in the oven;
- f) the results of the test as specified in [Clause 11](#);
- g) the name of the person who conducted the test;
- h) any deviations from the procedure specified;
- i) any unusual features (anomalies) observed during the test;
- j) the date of the test.

Annex A (informative)

Examples of test substances

Examples of laboratory chemicals and biological substances that can be used as test substances are given in [Tables A.1](#) and [A.2](#). Other test liquids may be used, by agreement between the interested parties.

The identification and/or composition of the products should be specified as given in [Tables A.1](#) and [A.2](#), unless otherwise agreed.

Use only analytical-grade chemicals.

Table A.1 — Laboratory chemicals

Test substance	Differing volumes of droplets (see 10.3)
Sodium hydroxide solution, with a mass fraction of 5 % sodium hydroxide (CAS-No 1310-73-2)	100 µl
Hydrochloric acid solution, with a mass fraction of 10 % hydrochloric acid (CAS-No 7647-01-0)	100 µl
Sulfurous acid solution, with a mass fraction of 6 % sulfurous acid (CAS-No 7782-99-2)	25 µl
Sulfuric acid solution, with a mass fraction of 10 % sulfuric acid (CAS-No 7664-93-9)	25 µl
Sulfuric acid solution, with a mass fraction of 36 % sulfuric acid (CAS-No 7664-93-9)	25 µl
Water, conforming to the requirements of Grade 3 of ISO 3696 ^[1]	100 µl

Table A.2 — Biological substances

Test substance	Comments	Differing volumes of droplets (see 10.3)
Resin	rosin, (CAS-No 8050-09-7, CAS-No 94114-23-5) 50 % (by mass)	25 µl
	pine oil (CAS-No 2228-95-7) 50 % (by mass)	
Fall-out test substance	e.g. formic acid (CAS-No 64-18-6) 47 % (by mass)	25 µl
	tannic acid (CAS-No 1401-55-4) 24 % (by mass)	
	albumin (CAS-No 9006-59-1) 5 % (by mass)	
	honey 24 % (by mass)	
Gum arabic	e.g. acacia gum (CAS-No 9000-01-5)	25 µl
^a Pancreatin may be ground in a mortar, if agreed between the interested parties. If the pancreatin is ground, this shall be stated in the test report.		

Test substance	Comments	Differing volumes of drop-lets (see 10.3)
Rosin (CAS-No 8050-09-7, CAS-No 94114-23-5)		25 µl
Simulated bird droppings	pancreatin (CAS-No 8049-47-6) ^a , 1:1 diluted with water conforming to the requirements of Grade 3 of ISO 3696 ^[1]	50 µl
^a Pancreatin may be ground in a mortar, if agreed between the interested parties. If the pancreatin is ground, this shall be stated in the test report.		

Bibliography

- [1] [ISO 3696](#), *Water for analytical laboratory use — Specification and test methods*